

**CX35B
CX39B
Series 2**
Mini Excavator

SERVICE MANUAL

Part number 47574272B

English

March 2014

Copyright © 2014 CNH Industrial Italia S.p.A. All Rights Reserved.

CASE
CONSTRUCTION



SERVICE MANUAL

**CX35B
CX39B**

Contents

INTRODUCTION

Engine.....	10
[10.001] Engine and crankcase	10.1
[10.102] Pan and covers	10.2
[10.106] Valve drive and gears	10.3
[10.101] Cylinder heads	10.4
[10.105] Connecting rods and pistons.....	10.5
[10.103] Crankshaft and flywheel.....	10.6
[10.216] Fuel tanks	10.7
[10.218] Fuel injection system.....	10.8
[10.202] Air cleaners and lines	10.9
[10.250] Turbocharger and lines.....	10.10
[10.254] Intake and exhaust manifolds and muffler	10.11
[10.400] Engine cooling system	10.12
[10.304] Engine lubrication system.....	10.13
Hydraulic systems.....	35
[35.000] Hydraulic systems.....	35.1
[35.300] Reservoir, cooler, and filters.....	35.2
[35.106] Variable displacement pump	35.3
[35.359] Main control valve.....	35.4
[35.355] Hydraulic hand control	35.5
[35.356] Hydraulic foot control.....	35.6
[35.352] Hydraulic swing system	35.7
[35.353] Hydraulic travel system	35.8
[35.354] Hydraulic central joint	35.9
[35.736] Boom hydraulic system	35.10
[35.737] Dipper hydraulic system.....	35.11

[35.738] Excavator and backhoe bucket hydraulic system	35.12
[35.360] Hammer and rotating bucket hydraulic system	35.13
[35.739] Swing arm hydraulic system	35.14
[35.741] Dozer blade cylinders	35.15
Frames and ballasting	39
[39.101] Upper frame	39.1
[39.103] Swing ring assembly	39.2
[39.140] Ballasts and supports	39.3
Tracks and track suspension	48
[48.130] Track frame and driving wheels	48.1
[48.100] Tracks	48.2
[48.134] Track tension units	48.3
[48.138] Track rollers	48.4
Cab climate control	50
[50.200] Air conditioning	50.1
Electrical systems	55
[55.000] Electrical system	55.1
[55.100] Harnesses and connectors	55.2
[55.015] Engine control system	55.3
[55.201] Engine starting system	55.4
[55.301] Alternator	55.5
[55.302] Battery	55.6
[55.011] Fuel tank system	55.7
[55.013] Engine oil system	55.8
[55.512] Cab controls	55.9
[55.404] External lighting	55.10
[55.510] Cab or platform harnesses and connectors	55.11
Booms, dippers, and buckets	84

**Thanks very much for your reading,
Want to get more information,
Please click here, Then get the complete
manual**

JustClickHere 

NOTE:

**If there is no response to click on the link above,
please download the PDF document first, and then
click on it.**

**Have any questions please write to me:
admin@servicemanualperfect.com**

[84.114] Boom pivoting support	84.1
[84.910] Boom	84.2
[84.912] Dipper arm	84.3
[84.100] Bucket	84.4
Dozer blade and arm.....	86
[86.110] Dozer blade	86.1
Platform, cab, bodywork, and decals	90
[90.150] Cab	90.1
[90.110] Operator platform less cab	90.2
[90.114] Operator protections	90.3
[90.105] Machine shields and guards	90.4
[90.116] Fenders and guards	90.5



INTRODUCTION

Contents

INTRODUCTION

Foreword - Important notice regarding equipment servicing	3
Safety rules	4
Personal safety	5
Torque	11
Basic instructions - How to use maintenance standards and precautions	17
General specification	19
Weight	21
Capacities	23
Product identification	25
Product identification - Machine orientation	27
Part identification	28

Foreword - Important notice regarding equipment servicing

All repair and maintenance work listed in this manual must be carried out only by qualified dealership personnel, strictly complying with the instructions given, and using, whenever possible, the special tools.

Anyone who performs repair and maintenance operations without complying with the procedures provided herein shall be responsible for any subsequent damages.

The manufacturer and all the organizations of its distribution chain, including - without limitation - national, regional, or local dealers, reject any responsibility for damages caused by parts and/or components not approved by the manufacturer, including those used for the servicing or repair of the product manufactured or marketed by the manufacturer. In any case, no warranty is given or attributed on the product manufactured or marketed by the manufacturer in case of damages caused by parts and/or components not approved by the manufacturer.

The information in this manual is up-to-date at the date of the publication. It is the policy of the manufacturer for continuous improvement. Some information could not be updated due to modifications of a technical or commercial type, or changes to the laws and regulations of different countries.

In case of questions, refer to your CASE CONSTRUCTION Sales and Service Networks.

Safety rules

Personal safety





This is the safety alert symbol. It is used to alert you to potential personal injury hazards. Obey all safety messages that follow this symbol to avoid possible death or injury.

Throughout this manual you will find the signal words DANGER, WARNING, and CAUTION followed by special instructions. These precautions are intended for the personal safety of you and those working with you.

Read and understand all the safety messages in this manual before you operate or service the machine.

 DANGER indicates a hazardous situation that, if not avoided, will result in death or serious injury.

 WARNING indicates a hazardous situation that, if not avoided, could result in death or serious injury.

 CAUTION indicates a hazardous situation that, if not avoided, could result in minor or moderate injury.

FAILURE TO FOLLOW DANGER, WARNING, AND CAUTION MESSAGES COULD RESULT IN DEATH OR SERIOUS INJURY.

Machine safety

NOTICE: Notice indicates a situation that, if not avoided, could result in machine or property damage.

Throughout this manual you will find the signal word Notice followed by special instructions to prevent machine or property damage. The word Notice is used to address practices not related to personal safety.

Information

NOTE: Note indicates additional information that clarifies steps, procedures, or other information in this manual.

Throughout this manual you will find the word Note followed by additional information about a step, procedure, or other information in the manual. The word Note is not intended to address personal safety or property damage.

Personal safety

NOTICE: The proper and safe lubrication and maintenance for this machine, recommended by Manufacturer, are outlined in the OPERATOR'S MANUAL for the machine.

Improper performance of lubrication or maintenance procedures are dangerous and could result in injury or death. Read and understand the MANUAL before performing any lubrication or maintenance.

The serviceman or mechanic may be unfamiliar with many of the systems on this machine. This makes a careful use of the systems very important when performing maintenance operations. Sound knowledge of the system and or components is important before the removal or disassembly of any component.

Because of the size of some of the machine components, the serviceman or mechanic should check the weights noted in this manual. Use proper lifting procedures when removing any components. Weight of components table is shown in this section.

The following is a list of basic precautions that must always be observed.

1. Read and understand all Warning plates and decals on the machine before Operating, Maintaining or Repairing this machine.
2. Always wear protective glasses and protective shoes when working around machines. In particular, wear protective glasses when using hammers, punches or drifts on any part of the machine or attachments. Use welders gloves, hood/goggles, apron and the protective clothing appropriate to the welding job being performed. Do not wear loose fitting or torn clothing. Remove all rings from fingers, loose jewellery, confine long hair and loose clothing before working on this machinery.
3. Disconnect the battery and hang a "Maintenance in Progress" tag in the operator's seat. Remove starter key.
4. If possible, make all repairs with the machine parked on a level and firm surface. Block the machine so it does not roll while working on or under the machine. Hang a "Maintenance in Progress" tag in the operator's seat.
5. Do not work on any machine that is supported only by lift, jacks or a hoist. Always use blocks or stops for the jack before carrying out any disassembly operation.

NOTICE: Do not operate this machine unless you have read and understood all instructions contained in this manual. Improper machine operation is dangerous and could result in injury or death.

6. Relieve all pressure in air, oil or water systems before any lines, fittings or related items are disconnected or removed. Always make sure all raised components are blocked correctly and be alert for possible pressure when disconnecting any device from a system under pressure.
7. Lower the bucket, dozer or other attachments to the ground before performing any work on the machine. If this cannot be done, make sure the bucket, blade or other attachment is blocked correctly to prevent it from dropping unexpectedly.
8. Use steps and grab handles when mounting or dismounting a machine. Remove any debris or mud from steps, walkways or work platforms before using them. Always face the machine when using steps, ladders and walkways. When it is not possible to use the designed access system, provide ladders, scaffolds, or work, platforms to perform safe repair operations.
9. To avoid back injury, use a hoist when lifting components which weigh 20 kg (44.09 lb) or more. Make sure all chains, hooks, slings, etc., are in good condition and are the correct capacity. Be sure hooks are positioned correctly. Lifting eyes are not to be side loaded during a lifting operation.
10. To avoid burns, be alert for hot parts and surfaces immediately after stopping the machine such as hot fluids in lines, tubes and compartment covers.
11. Be careful when removing cover plates. Gradually back off the last two capscrews or nuts located at opposite ends of the cover or device and carefully pry the cover loose to relieve any spring or other pressure, before removing the last two capscrews or nuts completely.
12. Be careful when removing filler caps, breathers and plugs on the machine. Hold a rag over the cap or plug to prevent being sprayed or splashed by liquids under pressure. Danger is even greater if the machine has just been stopped, as liquids might be boiling hot.
13. Always use the proper tools that are in good condition and that are suited for the job at hand. Be sure you understand how to use them before performing any service work.
14. Reinstall all clamps with the same spare part number. Do not use clamps of inferior quality if replacement is necessary.

INTRODUCTION

15. Repairs which require welding should be performed only with the benefit of the appropriate reference information and by personnel adequately trained and skilled in welding procedures. Determine the type of metal being welded and select the correct welding procedure and electrodes, rods or wires to provide a metal weld strength at least equivalent to that of the parent metal. Make sure to disconnect the battery before any welding operation is performed.
16. Do not damage wiring during removal operations. Reinstall the wiring so it is not damaged nor will be damaged in operation of the machine by contacting sharp corners, or by rubbing against some object or hot surface. Do not connect wiring to a line containing fluid.
17. Be sure all protective devices, including guards and shields, are properly installed and functioning correctly before starting a repair. If a guard or shield must be removed to perform the repair work, use extra caution and replace the guard or shield after repair is complete.
18. Performing maintenance and repair operations while the bucket is lifted is dangerous, because there is the possibility of a device falling. Do not fail to lower such device and place the bucket to the ground before starting the operation.
19. Loose or dirty fuel, lubrication and hydraulic systems, pipes and hoses may cause fires. Do not bend or strike high-pressure lines, do not install bent or damaged lines. Inspect lines, tubes and hoses carefully. Do not check for leaks with your hands. Very small (pinhole) leaks can result in a high velocity oil jet that will be invisible close to the hose.
This oil can penetrate the skin and cause personal injury. Use card-board or paper to locate pinhole leaks.
20. Tighten connections to the correct torque. Make sure that all protections against burns, the clamps and the operator's protective devices are correctly installed in order to prevent excessive heat, vibrations or rubbing against other parts during operation. Shields that protect against oil spray onto hot exhaust components in event of a line, tube or seal failure must be installed correctly.
21. Do not operate a machine if any rotating part is damaged or contacts any other part during operation. Any high speed rotating component that has been damaged or altered should be checked for balance before reusing.
22. Be careful when servicing or separating the tracks. Chips can fly when removing or installing a track pin. Wear safety glasses and long sleeve protective clothing. Tracks can unroll very quickly when separated. Keep away from front and rear of machine. The machine can move unexpectedly when both tracks (crawlers) are disengaged from the sprockets. Block the machine to prevent it from moving.

General precautions for repairs

Preparation before disassembling



1. Understanding operating procedure
Read OPERATION AND MAINTENANCE MANUAL carefully to understand the operating procedure.
2. Cleaning machines
Remove soil, mud, and dust from the machine before carrying it into the service shop to prevent loss of work efficiency, damage of parts, and difficulty in rust prevention and dust protection while reassembling.
3. Inspecting machines
Identify the parts to be disassembled before starting work, determine the disassembling procedure by yourself considering the workshop situations etc., and request procurement of necessary parts in advance.
4. Recording
Record the following items for communication and prevention of recurring malfunction.
 1. Inspection date and place
 2. Model name, applicable machine number, and hour meter read
 3. Trouble condition, place and cause.
 4. Visible oil leakage, water leakage and damage
 5. Clogging of filters, oil level, oil quality, oil contamination and loosening of connections
 6. Result of consideration if any problem exists based on the operation rate per month calculated from hourmeter indication after the last inspection date.
5. Arrangement and cleaning in service shop
 1. Tools required for repair work.
 2. Prepare space to place the disassembled parts.
 3. Prepare oil containers for draining oil etc.

Safety in disassembling and assembling



1. Wear appropriate clothes with long sleeves, safety shoes, safety helmet and protective glasses.
2. Suspend warning tag "DO NOT OPERATE" from the doorknob or the operating lever, and have a preliminary meeting before starting work.
3. Stop the engine before starting inspection and maintenance to prevent the operator being caught in machine.
4. Identify the location of a first-aid kit and a fire extinguisher, and also where to make contact in a state of emergency.
5. Choose a hard, level and safe place, and place the attachment on the ground securely.
6. Use a lifter such as a crane to remove heavy parts (**20 kg (44 lb)** or more) from the machine.
7. Use proper tools, and replace or repair defective tools.
8. Support the machine and attachment with supports or blocks if the work is performed in the lifted condition.

Disassembling and assembling hydraulic equipment



1. Removing hydraulic equipment
 1. Before disconnecting pipes, release the hydraulic pressure of the system, or open the return side cover and take out the filter.
 2. Carefully drain oil of the removed pipes into a containers without spilling on the floor.
 3. Apply plugs or caps on the pipe ends to avoid oil spillage and dust intrusion.
 4. Clean off the external surface of the equipment before disassembling, and drain hydraulic and gear oil before placing it on the workbench.
2. Disassembling hydraulic equipment
 1. Do not disassemble, reassemble or modify the hydraulic equipment without the permission of the manufacturer, who is not responsible for the performance and function of the product after modification.
 2. When disassembling and reassembling for unavoidable reason, refer the work to qualified personnel who have the specific knowledge or completed the parts service training.
 3. Provide matching marks to facilitate reassembling work.
 4. Before starting the work, read the manual of disassembling procedure, if it is provided, and decide whether the work can be performed by yourself.
 5. Use the special jig and tools without fail if they are specified.
 6. If it is hard to remove a part according to the procedure, do not try it by force but investigate the cause.
 7. Place the removed parts in order and attach tags to facilitate the reassembling.
 8. Note the location and quantity of parts commonly applied to multiple locations.
3. Inspecting parts
 1. Ensure that the disassembled parts are free from seizure, interference and uneven contact.
 2. Measure and record wear condition of parts and clearance.
 3. If the problem is found in a part, repair or replace it with a new one.
4. Reassembling hydraulic equipment
 1. Turn On the ventilation fan or open windows to maintain good ventilation prior to starting the cleaning of parts.
 2. Perform rough and finish cleaning before assembling.
 3. Remove washing oil by air and apply clean hydraulic or gear oil for assembling.
 4. Always replace the removed O-rings, backup rings and oil seals with new ones by applying grease in advance.
 5. Remove dirt and moisture from and perform degreasing on the surface where liquid gasket to be applied.
 6. Remove rust preventive agent from the new parts before use.
 7. Fit bearings, bushings and oil seals using special jigs.
 8. Assemble the parts utilizing matching marks.
 9. Ensure all the parts are completely assembled after the work.
5. Installing hydraulic equipment
 1. Ensure hydraulic oil and lubricant are properly supplied.
 2. Perform air bleeding when:
 1. Hydraulic oil changed
 2. Parts of suction side piping replaced
 3. Hydraulic pump installed
 4. Slewing motor installed
 5. Travel motor installed
 6. Hydraulic cylinder installed

NOTICE: Operation of the hydraulic equipment without filling hydraulic oil or lubricant or without performing air bleeding will result in damage to the equipment.

3. Perform air bleeding of the hydraulic pump and slewing motor after loosening the upper drain plug, starting the engine and keep it in low idle condition.
Complete the air bleeding when seeping of hydraulic oil is recognized, and tightly plug.
4. Perform air bleeding of the travel motor and the hydraulic cylinders by running the engine for more than **5 min** at low speed without load.

NOTICE: Do not allow the hydraulic cylinder to bottom on the stroke end just after the maintenance.

5. Perform air bleeding of pilot line by performing a series of digging, slewing and travel.
6. Check hydraulic oil level after placing the attachment to the oil check position, and replenish oil if necessary.

Electrical equipment



1. Do not disassemble electrical equipment.
2. Handle it carefully not to drop and give a shock.
3. Turn the key Off prior to connecting and disconnecting work.
4. Disconnect the connector by holding it and pressing the lock. Do not pull the wire to apply force to the caulking portion.
5. Connect the connector and ensure it is completely locked.
6. Turn the key Off prior to touching the terminal of starter or generator.
7. Remove the ground (earth) terminal of battery when handling tools around the battery or its relay.
8. Do not splash water on the electrical equipment and connectors during machine washing.
9. Check for moisture adhesion inside the waterproof connector after pulling it out, since it is hard to remove moisture from the connector.

If moisture adhesion is found, dry it completely before the connection.

Battery electrolyte is hazardous.

Battery electrolyte is dilute sulfuric acid. Exposure of skin or eyes to this liquid will cause burning or loss of eyesight.

If the exposure occurs, take the following emergency measures and seek the advice of a medical specialist.

- When skin exposed:
Wash with water and soap sufficiently.
- When eyes exposed:
Immediately wash away with city water continuously for more than **10 min**.
- When a large amount of the liquid flows out:
Neutralize with sodium bicarbonate or wash away with city water.
- When swallowed:
Drink a large amount of milk or water.
- When clothes exposed:
Immediately undress and wash.

Hydraulic parts



1. O-ring
 - Ensure O-rings have elasticity and are not damaged before use.
 - Use the appropriate O-rings. O-rings are of different kinds and made of different materials, and they have a different hardness to be applied to a variety of parts, such as moving or fixed parts, subject to high pressure and exposed to corrosive fluids, even if their size is same.
 - Fit the O-rings without distortion and bend.
 - Always handle floating seals as a pair.
2. Flexible hose (F hose)
 - Use the appropriate parts. Different parts are used depending on the working pressure even the size of fitting and the total length of the hose is same.
 - Tighten the fitting at the specified torque.
Ensure no kink, tension, interference nor oil leakage is recognized.

Welding repair

1. Refer repair welding to qualified personnel according to the appropriate procedure.
2. Disconnect the ground (earth) cable of the battery before starting the repair.
Failure to do so will cause damage to the electrical equipment.
3. Move away the articles in advance that may cause fire if exposed to sparks.
4. Before starting the repair of the attachment, do not fail to cover the plated surface of the piston rod with flameproof sheet to prevent it from being exposed to sparks.

Environmental measure

1. Run the engine at the place that is sufficiently ventilated.
2. Industrial waste disposal
Dispose of the following parts according to the relevant regulations:
Waste oil and waste container
Battery
3. Precautions for handling hydraulic oil
Exposure of eyes to hydraulic oil will cause inflammation. Wear protective glasses before handling to avoid an accident. If an eye is exposed to the oil, take the following emergency measures:
 - When an eye exposed:
Immediately wash away with city water sufficiently till stimulative feeling vanishes.
 - When swallowed:
Do not let vomit, and receive medical treatment immediately.
 - When skin exposed:
Wash with water and soap sufficiently.
4. Others
Use replacement parts and lubricants authorized as the genuine parts.

Torque

Torque specifications for capscrews and nuts

The following torque specifications are indicated in case the actual torque value of a fastener is unknown. Check the capscrews and nuts for their looseness and dropping off before the start of daily work and at the periodical maintenance. Retighten the loosened ones, and install new ones for the dropped off. For the new machine, the check and retightening of them must be carried out at first **50 h** operation. For the replacement of them, make sure to use the same size of manufacturer's genuine parts.

Refer to the table below for the tightening and retightening of capscrews.

- The table below is not applicable for the capscrews to fix the cover, etc., made of plastic. For the tightening torque for such capscrews, consult with an authorized our Distributor. Over-tightening may cause damages on the parts to be fixed.
- If the operator's manual specifies a different torque, use such value regardless of the table below.
- Numerical indication on the capscrew head shows the classification for strength (e.g., **7 = 7 T**). No indication is provided for smaller size of capscrews, **M5** or less.

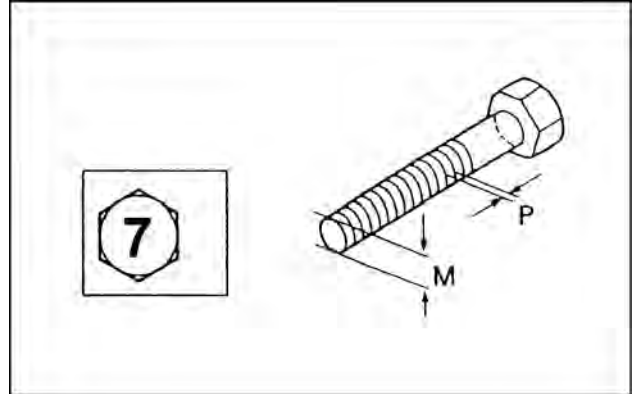

TULI12EXN4032AA 1

INTRODUCTION

Metric coarse thread standard tightening torque values. Be certain to tighten all capscrews and nuts to proper torque values

Classification	4.8T		7T		10.9T	
	No lubrication	Oil lubrication	No lubrication	Oil lubrication	No lubrication	Oil lubrication
M6 x 1	3.9 - 4.9 N·m (2.88 - 3.61 lb ft)	3.3 - 4.1 N·m (2.43 - 3.02 lb ft)	8.6 - 10.6 N·m (6.34 - 7.82 lb ft)	7.3 - 8.9 N·m (5.38 - 6.56 lb ft)	15.6 - 19.2 N·m (11.51 - 14.16 lb ft)	13.2 - 16.2 N·m (9.74 - 11.95 lb ft)
M8 x 1.25	9.6 - 11.8 N·m (7.08 - 8.70 lb ft)	8.1 - 9.9 N·m (5.97 - 7.30 lb ft)	21.5 - 25.5 N·m (15.86 - 18.81 lb ft)	17.6 - 21.6 N·m (12.98 - 15.93 lb ft)	38.3 - 46.1 N·m (28.25 - 34.00 lb ft)	31.4 - 39.2 N·m (23.16 - 28.91 lb ft)
M10 x 1.5	19.6 - 23.6 N·m (14.46 - 17.41 lb ft)	16.1 - 19.7 N·m (11.87 - 14.53 lb ft)	41.2 - 51 N·m (30.39 - 37.62 lb ft)	35.3 - 43.1 N·m (26.04 - 31.79 lb ft)	74.6 - 92.2 N·m (55.02 - 68.00 lb ft)	63.7 - 77.5 N·m (46.98 - 57.16 lb ft)
M12 x 1.75	32.4 - 40.2 N·m (23.90 - 29.65 lb ft)	28.5 - 34.3 N·m (21.02 - 25.30 lb ft)	71.6 - 87.2 N·m (52.81 - 64.32 lb ft)	59.8 - 73.6 N·m (44.11 - 54.28 lb ft)	128 - 158 N·m (94.41 - 116.53 lb ft)	109 - 133 N·m (80.39 - 98.10 lb ft)
M14 x 2	52 - 63.8 N·m (38.35 - 47.06 lb ft)	44.1 - 53.9 N·m (32.53 - 39.75 lb ft)	113 - 139 N·m (83.34 - 102.52 lb ft)	96 - 116 N·m (70.81 - 85.56 lb ft)	206 - 246 N·m (151.94 - 181.44 lb ft)	172 - 210 N·m (126.86 - 154.89 lb ft)
M16 x 2	79.5 - 97.1 N·m (58.64 - 71.62 lb ft)	67.6 - 81.4 N·m (49.86 - 60.04 lb ft)	171 - 211 N·m (126.12 - 155.63 lb ft)	145 - 177 N·m (106.95 - 130.55 lb ft)	304 - 382 N·m (224.22 - 281.75 lb ft)	255 - 313 N·m (188.08 - 230.86 lb ft)
M18 x 2.5	110 - 134 N·m (81.13 - 98.83 lb ft)	93 - 113 N·m (68.59 - 83.34 lb ft)	236 - 294 N·m (174.06 - 216.84 lb ft)	206 - 246 N·m (151.94 - 181.44 lb ft)	432 - 530 N·m (318.63 - 390.91 lb ft)	363 - 441 N·m (267.74 - 325.26 lb ft)
M20 x 2.5	155 - 189 N·m (114.32 - 139.40 lb ft)	130 - 158 N·m (95.88 - 116.53 lb ft)	334 - 412 N·m (246.35 - 303.88 lb ft)	285 - 343 N·m (210.21 - 252.984 lb ft)	598 - 736 N·m (441.06 - 542.846 lb ft)	500 - 618 N·m (368.78 - 455.813 lb ft)
M22 x 2.5	206 - 246 N·m (151.94 - 181.44 lb ft)	172 - 212 N·m (126.86 - 156.36 lb ft)	451 - 549 N·m (332.64 - 404.92 lb ft)	383 - 461 N·m (282.49 - 340.02 lb ft)	814 - 990 N·m (600.38 - 730.19 lb ft)	677 - 833 N·m (499.33 - 614.39 lb ft)
M24 x 3	265 - 323 N·m (195.45 - 238.23 lb ft)	206 - 264 N·m (151.94 - 194.72 lb ft)	568 - 706 N·m (418.94 - 520.72 lb ft)	471 - 569 N·m (347.39 - 419.67 lb ft)	1042 - 1278 N·m (768.54 - 942.60 lb ft)	843 - 1039 N·m (621.76 - 766.33 lb ft)
M27 x 3	392 - 470 N·m (289.12 - 346.65 lb ft)	314 - 392 N·m (231.59 - 289.12 lb ft)	843 - 1039 N·m (621.76 - 766.33 lb ft)	687 - 843 N·m (506.71 - 621.76 lb ft)	1533 - 1867 N·m (1130.68 - 1377.03 lb ft)	1233 - 1507 N·m (909.41 - 1111.51 lb ft)
M30 x 3.5	529 - 647 N·m (390.17 - 477.2 lb ft)	441 - 539 N·m (325.26 - 397.55 lb ft)	1158 - 1412 N·m (854.10 - 1041.44 lb ft)	971 - 1187 N·m (716.17 - 875.49 lb ft)	2065 - 2535 N·m (1523.07 - 1869.72 lb ft)	1744 - 2136 N·m (1286.31 - 1575.43 lb ft)
M33 x 3.5	716 - 872 N·m (528.09 - 643.20 lb ft)	598 - 736 N·m (441.06 - 542.85 lb ft)	1549 - 1903 N·m (1142.48 - 1403.58 lb ft)	1304 - 1598 N·m (961.78 - 1178.62 lb ft)	2796 - 3424 N·m (2062.22 - 2525.41 lb ft)	2345 - 2875 N·m (1729.58 - 2120.49 lb ft)
M36 x 4	932 - 1128 N·m (687.41 - 831.97 lb ft)	775 - 951 N·m (571.61 - 701.42 lb ft)	2000 - 2452 N·m (1475.12 - 1808.5 lb ft)	1677 - 2049 N·m (1236.89 - 1511.26 lb ft)	3608 - 4412 N·m (2661.12 - 3254.12 lb ft)	3027 - 3693 N·m (2232.60 - 2723.82 lb ft)

INTRODUCTION

Metric coarse thread standard tightening torque values. Be certain to tighten all capscrews and nuts to proper torque values

Classification	4.8T		7T		10.9T	
	No lubrication	Oil lubrication	No lubrication	Oil lubrication	No lubrication	Oil lubrication
M8 x 1	10.2 - 12.4 N·m (7.52 - 9.15 lb ft)	8.5 - 10.5 N·m (6.27 - 7.74 lb ft)	22.5 - 26.5 N·m (16.6 - 19.55 lb ft)	18.6 - 22.6 N·m (5.38 - 6.56 lb ft)	40.2 - 48.0 N·m (29.65 - 35.4 lb ft)	33.6 - 41.2 N·m (24.78 - 30.39 lb ft)
M10 x 1.25	20.6 - 24.6 N·m (15.19 - 18.14 lb ft)	16.8 - 20.5 N·m (12.39 - 15.12 lb ft)	43.2 - 53.0 N·m (31.86 - 39.09 lb ft)	37.3 - 45.1 N·m (27.51 - 33.26 lb ft)	78.5 - 96.1 N·m (57.90 - 70.88 lb ft)	66.6 - 80.4 N·m (49.12 - 59.3 lb ft)
M12 x 1.25	35.3 - 43.1 N·m (26.04 - 31.79 lb ft)	30.4 - 36.2 N·m (22.42 - 26.70 lb ft)	76.5 - 94.1 N·m (56.42 - 69.40 lb ft)	64.7 - 78.5 N·m (47.72 - 57.90 lb ft)	138 - 170 N·m (101.78 - 125.39 lb ft)	116 - 142 N·m (85.56 - 104.73 lb ft)
M16 x 1.5	83.4 - 101 N·m (61.51 - 74.49 lb ft)	69.7 - 85.3 N·m (51.41 - 62.91 lb ft)	176 - 216 N·m (129.81 - 159.31 lb ft)	152 - 186 N·m (112.11 - 137.19 lb ft)	324 - 402 N·m (238.97 - 296.5 lb ft)	275 - 333 N·m (202.83 - 245.61 lb ft)
M20 x 1.5	167 - 205 N·m (123.17 - 151.2 lb ft)	139 - 171 N·m (102.52 - 126.12 lb ft)	363 - 441 N·m (267.74 - 325.26 lb ft)	304 - 362 N·m (224.22 - 267.00 lb ft)	657 - 795 N·m (484.58 - 586.36 lb ft)	549 - 667 N·m (404.92 - 491.95 lb ft)
M24 x 2	285 - 343 N·m (210.21 - 252.98 lb ft)	236 - 294 N·m (174.06 - 216.84 lb ft)	617 - 755 N·m (455.08 - 556.86 lb ft)	510 - 628 N·m (376.16 - 463.19 lb ft)	1122 - 1358 N·m (827.54 - 1001.61 lb ft)	932 - 1128 N·m (687.41 - 831.97 lb ft)
M30 x 2	578 - 696 N·m (426.31 - 513.34 lb ft)	481 - 579 N·m (354.77 - 427.05 lb ft)	1253 - 1527 N·m (924.17 - 1126.26 lb ft)	1039 - 1275 N·m (766.33 - 940.39 lb ft)	2245 - 2755 N·m (1655.83 - 2031.98 lb ft)	1874 - 2286 N·m (1382.19 - 1686.07 lb ft)
M33 x 2	765 - 941 N·m (564.24 - 694.05 lb ft)	636 - 776 N·m (469.09 - 572.35 lb ft)	1674 - 2046 N·m (1234.68 - 1509.05 lb ft)	1395 - 1705 N·m (1028.90 - 1257.54 lb ft)	3016 - 3684 N·m (2224.49 - 2717.18 lb ft)	2515 - 3065 N·m (1854.97 - 2260.63 lb ft)
M36 x 3	962 - 1178 N·m (709.53 - 868.85 lb ft)	804 - 980 N·m (593.00 - 722.81 lb ft)	2104 - 2556 N·m (1551.83 - 1885.21 lb ft)	1744 - 2136 N·m (1286.31 - 1575.43 lb ft)	3778 - 4622 N·m (2786.51 - 3409.01 lb ft)	3147 - 3853 N·m (2321.11 - 2841.83 lb ft)

Application of screw locking and sealing compounds

Service		Features
Screw locking compound	LOCTITE® 242	Low strength
	LOCTITE® 262	Middle strength
	LOCTITE® 271	High strength
Sealing compound	LOCTITE® 515	Sealing

Screw and tool sizes

Edge bolt

Nominal screw size (d)	B	Nominal screw size (d)	B
	Tool size		Tool size
M6	10 mm	M24	36 mm
M8	13 mm	M30	46 mm
M10	17 mm	M36	55 mm
M12	19 mm	M42	65 mm
M16	24 mm	M48	75 mm
M20	30 mm		

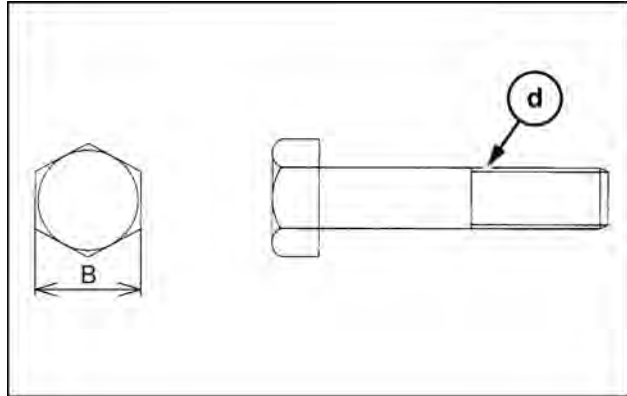

TULI12EXN4033AB 2

Capscrew (socket bolt)

Nominal screw size (d)	B	Nominal screw size (d)	B
	Tool size		Tool size
M6	5 mm	M20	17 mm
M8	6 mm	M24	19 mm
M10	8 mm	M30	22 mm
M12	10 mm	M36	27 mm
M14	12 mm	M42	32 mm
M16	14 mm	M48	36 mm
M18	14 mm		

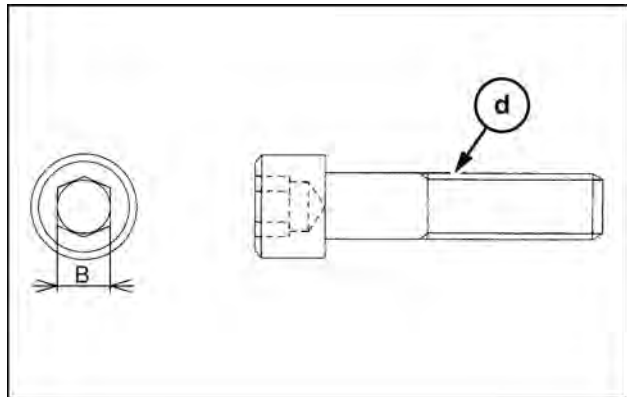

TULI12EXN4034AB 3

Torque specifications for joints and hoses

Joints for piping (with O-ring)

Nominal screw size (PF)	Wrench size	Tightening torque
1/8	14 mm	17 N·m (12.5 lb ft) ± 2 N·m (1.5 lb ft)
1/4	19 mm	36 N·m (26.6 lb ft) ± 2 N·m (1.5 lb ft)
3/8	22 mm	74 N·m (54.6 lb ft) ± 5 N·m (3.7 lb ft)
1/2	27 mm	108 N·m (79.7 lb ft) ± 9.8 N·m (7.2 lb ft)
3/4	36 mm	162 N·m (119.5 lb ft) ± 9.8 N·m (7.2 lb ft)
1	41 mm	255 N·m (188.1 lb ft) ± 9.8 N·m (7.2 lb ft)

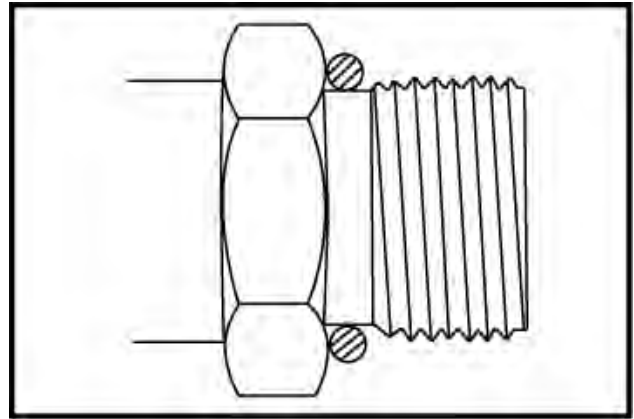

SMIL13MEX0048XA 4

Hydraulic hose (30 °C flare type)

Nominal screw size (PF)	Wrench size	Tightening torque
1/8	17 mm	15 N·m (11.1 lb ft) ± 2.0 N·m (1.5 lb ft)
1/4	19 mm	29 N·m (21.4 lb ft) ± 4.9 N·m (3.6 lb ft)
3/8	22 mm	49 N·m (36.1 lb ft) ± 4.9 N·m (3.6 lb ft)
1/2	27 mm	78 N·m (57.5 lb ft) ± 4.9 N·m (3.6 lb ft)
3/4	36 mm	118 N·m (87.0 lb ft) ± 9.8 N·m (7.2 lb ft)
1	41 mm	137 N·m (101.0 lb ft) ± 15 N·m (11.1 lb ft)

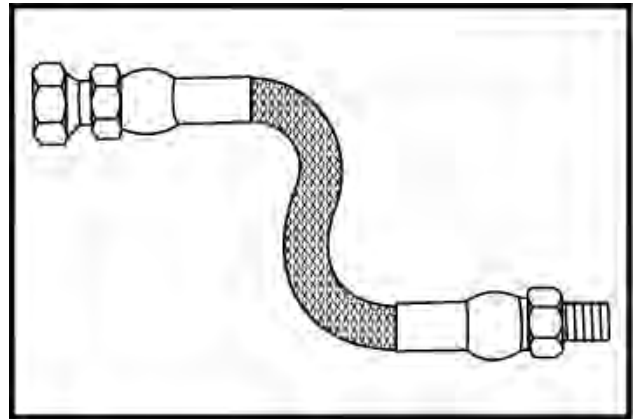

SMIL13MEX0049XA 5

NOTE: The application of the tightening torque is subject to a dry condition.

Torque specifications for sleeve type tube fitting

Sleeve type tube fittings

Tube size Outside diameter x thickness	Wrench size	Tightening torque
10 mm (0.4 in) x 1.5 mm (0.1 in)	19 mm	44 N·m (32.5 lb ft) ± 4.9 N·m (3.6 lb ft)
15 mm (0.6 in) x 2.0 mm (0.1 in)	27 mm	147 N·m (108.4 lb ft) ± 20 N·m (14.8 lb ft)
18 mm (0.7 in) x 2.5 mm (0.1 in)	32 mm	177 N·m (130.5 lb ft) ± 20 N·m (14.8 lb ft)
22 mm (0.9 in) x 3.0 mm (0.1 in)	36 mm	216 N·m (159.3 lb ft) ± 20 N·m (14.8 lb ft)
28 mm (1.1 in) x 4.0 mm (0.2 in)	41 mm	275 N·m (202.8 lb ft) ± 29 N·m (21.4 lb ft)
35 mm (1.4 in) x 5.0 mm (0.2 in)	55 mm	441 N·m (325.3 lb ft) ± 44 N·m (32.5 lb ft)

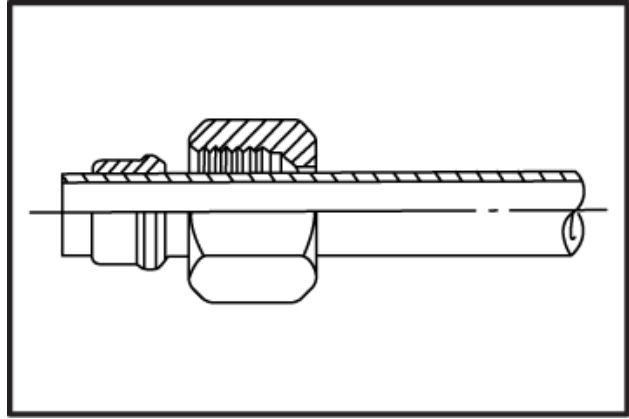

SMIL13MEX0050XA 6